

Physics 321
Take-home Test 3

Problem 1.

A cart of mass M (including four wheels each of moment of inertia I_1 and radius r .) is attached by a spring of constant k to a wall. The center of the cart is X from its position when the spring is unstretched. The top of the cart has a circular cross-section of radius R , as shown. A sphere of moment of inertia I_2 , mass m , and radius a is free to move along this surface of the cart. (We assume its motion is confined to the X - Y plane.) The angle of the sphere with respect to the vertical is θ ($\theta = 0$ is down). Let x be the distance of the sphere from the $X = 0$ position, and y be the position of the sphere from the center of curvature of the top of the cart, as illustrated. The angle the sphere rotates about its center of mass is ϕ . The sphere is moved to $\theta = 30$ degrees and released from rest. Using the Lagrangian formalism, find the motion of the cart and plot $X(t)$ and $\theta(t)$.

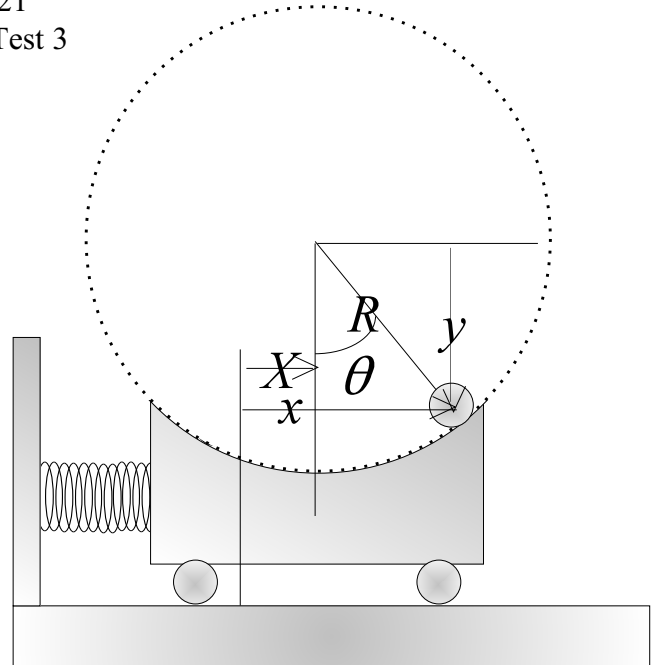

The following values are given:

- $M = 2.40 \text{ kg}$
- $m = 0.400 \text{ kg}$
- $I_1 = 0.900 \times 10^{-4} \text{ kg m}^2$
- $R = 0.500 \text{ m}$
- $a = 0.010 \text{ m}$
- $r = 0.020 \text{ m}$
- $k = 4 \text{ N/m}$

Problem 2.

A cart of mass M is attached to a wall by a spring of spring constant K . On top of the cart is a second cart of mass m attached to the front wall of the cart by a spring of spring constant k . The motion of the carts are restricted to the x direction. The following data are given:

$M = 12.5$ kg including the mass of the wheels.

$m = 2.50$ kg including the mass of the wheels.

$K = 12.00$ N/m

$k = 6.00$ N/m

$MI = 0.00025$ kg m^2 is the moment of inertia for each wheel. Each cart has four wheels.

$R = 1.20$ cm is the radius of each wheel

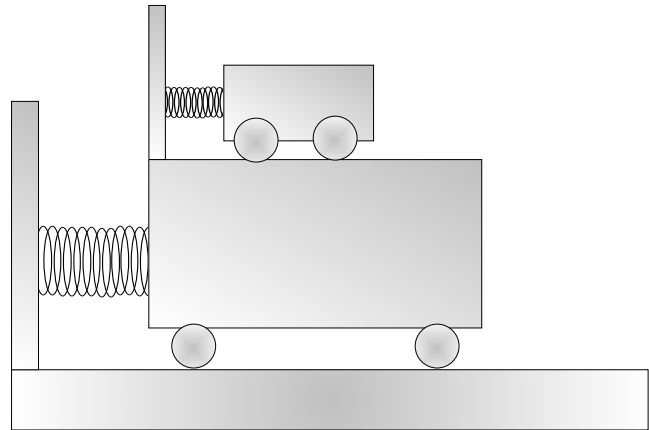

Let

x be the coordinate of the small cart with respect to the large cart

X be the coordinate of the large cart with respect to the ground

When the springs are unstrched, $X=x=0$

The large cart is moved to position X_0 and released from rest.