

Due: Monday, May 4

Physics 123
Lab #1
Pressure in a Fluid

Identification number _____

In this lab you will measure the density of an unknown liquid. You do this by forcing the liquid up a tube using a known amount of pressure (see figure).

Pressurize the bottle of liquid by squeezing the hand pump repeatedly. The liquid should be forced up the tube. Be sure that the silver air release valve is closed (twist it clockwise). Increase the pressure until the level of the liquid in the tube is almost 2 m above the floor. If you overshoot 2 m, you may lower the level of the liquid by opening the air release valve (twist it counter-clockwise).

Using the 2-meter stick, measure h_1 and h_2 (relative to the bottom of the bottle) and calculate $\Delta h = h_2 - h_1$. Record the results below. Record the pressure measured by the gauge. (Note that this is the pressure $P - P_0$ relative to the atmospheric pressure P_0 . Also note that the units of pressure measured by the gauge is oz/in². 16 oz = 1 lb.) Using $P = P_0 + \rho gh$, calculate the density ρ of the liquid and record the result below. Your result should be accurate to the nearest 0.01 g/cm³. Please release the air pressure when you are finished.

$h_1 =$ _____

$h_2 =$ _____

$h =$ _____

$P - P_0 =$ _____

$\rho =$ _____

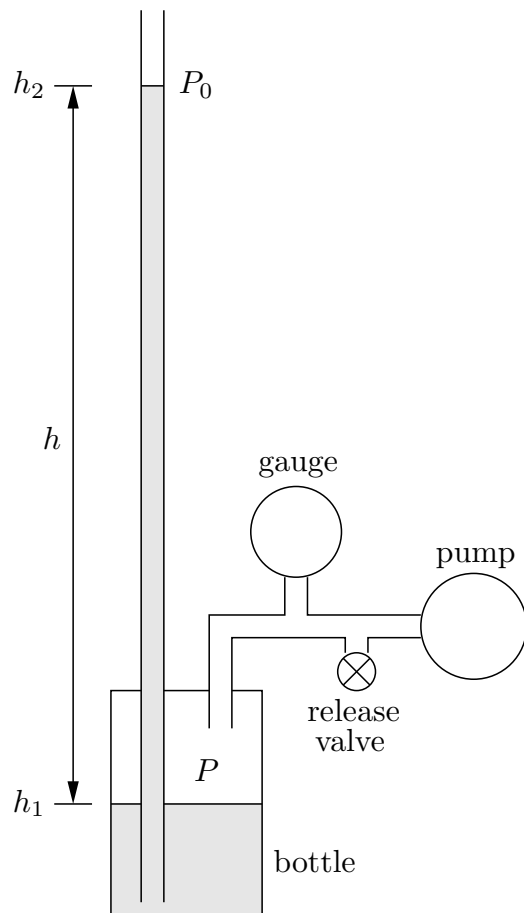

Due: Friday, May 8

Physics 123

Identification number _____

Lab #2

Standing Waves in a Wire

In this lab, you will produce standing waves in a wire. This is done by placing the wire through the poles of a magnet and passing an alternating current (60.00 Hz) through the wire. The resulting force of the magnetic field on the current drives the wire into a vertical oscillation at 60.00 Hz. The tension in the wire is equal to the weight hanging at the end. At certain tensions, the wire will resonate and produce visible standing waves.

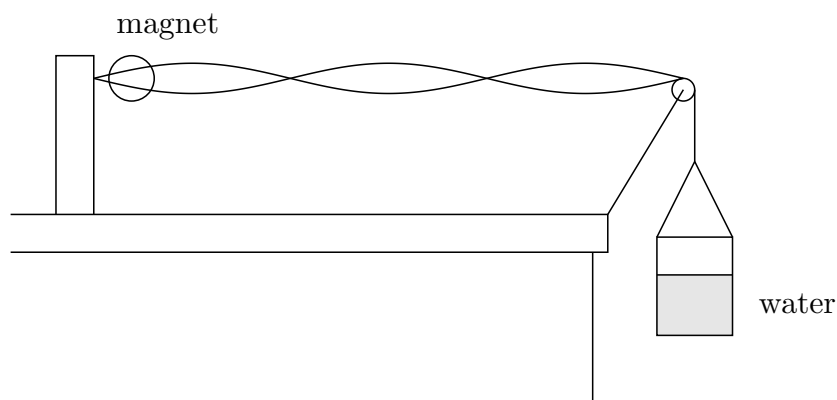

Produce a standing wave by adjusting the amount of water in the container and thus changing the tension in the wire. (Don't add any additional weight beside water. You may break the wire.) Adjust the tension until the amplitude of the antinodes is as large as possible (even though the nodes may not be as well defined). Using a meter stick, measure the wavelength λ of the standing wave. Calculate the velocity v of the waves in the wire. Weigh the container of water to obtain its mass m . Calculate the tension F in the wire. From F and v , calculate the linear mass density μ of the wire. Repeat this for a different standing wave.

	1st Standing Wave	2nd Standing Wave
$\lambda =$	_____	_____
$v =$	_____	_____
$m =$	_____	_____
$F =$	_____	_____
$\mu =$	_____	_____

Due: Friday, May 8

Physics 123

Identification number _____

Lab #3

Standing Waves in a Pipe

In this lab, you will produce standing waves in a pipe. This is done by placing a speaker at an open end of the pipe and driving the speaker with an oscillator as shown below:

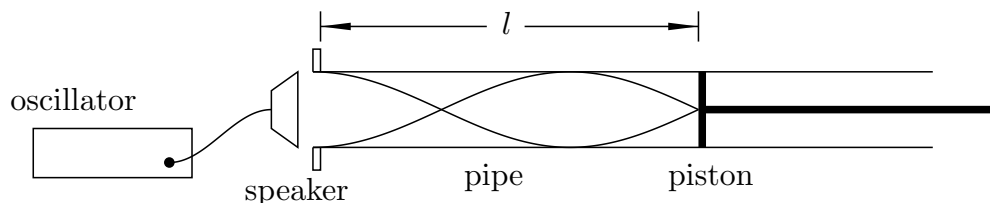

A piston is inserted into the other end of the pipe. At certain positions of the piston, the speaker will cause the pipe to resonate, thus producing standing waves.

Set the frequency f of the oscillator at approximately 700 Hz. Read the frequency shown on the counter and record it below. Starting with the piston at the end of the pipe, push it in slowly. You will notice that at certain positions, the sound of the speaker is enhanced. This is caused by standing waves in the pipe. Use the sound meter to accurately determine the position of the piston where the enhanced sound is loudest. Measure the distance l between the piston and the open end of the pipe at all positions of the piston for which this occurs and record it below. You ought to find 5 of them.

For each standing wave, the piston is at a position of a displacement node. From the data, you can thus obtain the distance between nodes and consequently the wavelength λ . Using the wavelength and frequency, calculate the velocity of sound to the nearest m/s (three significant figures). Record these results below.

$$f = \underline{\hspace{2cm}}$$

$$l = \underline{\hspace{1cm}} \quad \underline{\hspace{1cm}} \quad \underline{\hspace{1cm}} \quad \underline{\hspace{1cm}} \quad \underline{\hspace{1cm}}$$

$$\lambda = \underline{\hspace{2cm}}$$

$$v = f\lambda = \underline{\hspace{2cm}}$$

Due: Friday, May 15

Physics 123

Identification number _____

Lab #4

Heat Capacity of a Solid

In this lab, you will measure the specific heat of aluminum. A strap is wound around an aluminum cylinder of mass m and radius r . One end of the strap is attached to a weight Mg , and the other end is secured to a fixed support. As you turn the cylinder, the weight is lifted up slightly. The strap slips around the cylinder, and the weight is lifted due to a frictional force Mg between the strap and cylinder. When you turn the cylinder one revolution, the work done by the friction is equal to $W = (Mg)(2\pi r)$. This work becomes heat which causes the temperature of the cylinder to rise.

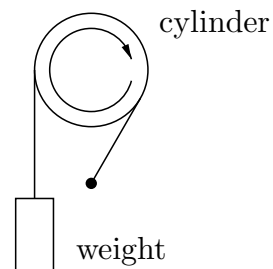

The temperature of the cylinder is measured using a solid-state device called a thermistor which is embedded in the cylinder. The temperature is obtained by measuring the resistance of the thermistor. A chart at the lab will give you the relation between the resistance of the thermistor and its temperature.

In order to minimize the effect of the heat flow between the cylinder and the surrounding air, we first cool down the cylinder to a few degrees below room temperature. This is done by pressing the piece of cold aluminum supplied with the apparatus against the rotating cylinder until the resistance of the thermistor is about 4 k Ω . (Be patient; this may take a while.) If you go too far, you can warm up the cylinder by pressing your warm hands on it.

Record the initial resistance R_i below. Turn the crank on the cylinder. As you do so, you will observe the temperature of the cylinder rising. Count the number of revolutions of the crank. Note that every revolution of the crank produces 12 revolutions of the cylinder. Stop when the resistance of the thermistor is about 2.5 k Ω . This will require about 100 revolutions of the crank. Record the final resistance R_f . Also record the number N of revolutions of the *cylinder*. (Multiply the number of revolutions of the crank by 12.) Using the chart provided, find the initial temperature T_i and the final temperature T_f and calculate the change in temperature ΔT . The values of M , m , and r will be given to you in the lab. Record them below. Calculate the work W per revolution done. Calculate the total work W done. Calculate the specific heat c of the cylinder.

$R_i =$ _____ $T_i =$ _____

$R_f =$ _____ $T_f =$ _____

$\Delta T =$ _____ $N =$ _____

$M =$ _____ $m =$ _____ $r =$ _____

$W/\text{revolution} =$ _____ total $W =$ _____ $c =$ _____

Due: Friday, May 29

Physics 123

Identification number _____

Lab #5

Brewster's Angle

In this lab, you will measure the Brewster angle for two different materials. From these measurements, you will then calculate the index of refraction for each material.

As shown in the figure below, a laser beam is directed towards the flat surface of a sample. The sample is mounted on a platform which can be rotated. The pointer attached to the platform points in a direction perpendicular to the surface of the sample. The incident angle θ of the beam can be read from a scale on the apparatus.

The reflected beam passes through a sheet of Polaroid and hits a white screen. The transmission axis of the Polaroid is horizontal. When the angle of the incident beam is equal to the Brewster angle, the reflected beam is polarized vertically and thus will not pass through the Polaroid. At this angle, the illuminated spot on the screen will disappear. (Actually, since the sample and the Polaroid are not ideal, the spot will not disappear completely, but will have a minimum intensity.)

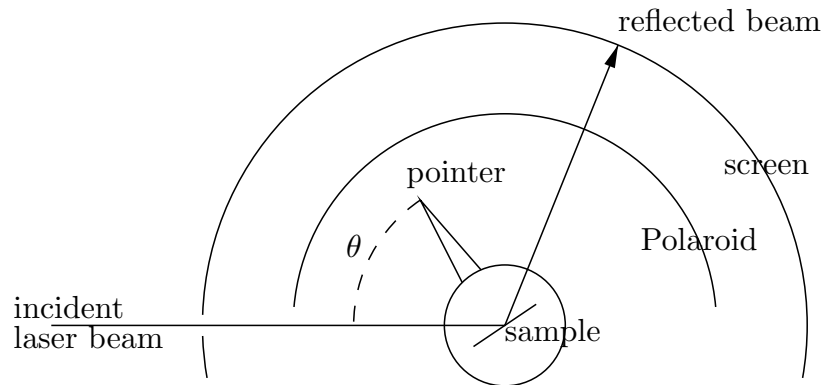

There are two samples. One is ordinary glass, and the other is zirconium oxide (ZrO_2). First insert the glass into the sample holder. Rotate the sample platform and find the orientation where the reflected beam has a minimum intensity. Be sure that the Polaroid sheet is in place so that the reflected beam passes through it. Read the incident angle from the scale and record it below. This is the Brewster's angle θ_p . Determine the index of refraction from $n = \tan \theta_p$ and record it below. Repeat this for the ZrO_2 sample.

Warning: Do not touch the sample surfaces. Finger prints on the samples will affect your measurements. Wipe off any finger prints with the tissues provided.

Glass sample: $\theta_p =$ _____ $n =$ _____

ZrO_2 sample: $\theta_p =$ _____ $n =$ _____

When you are finished, remove the Polaroid sheet and notice how intense the reflected beam is. Then place a small circular Polaroid sheet in the path of the reflected beam and observe how its intensity changes as you rotate the sheet.

Due: Friday, May 29

Physics 123
Lab #6
Telescope

Identification number _____

In this lab, you will construct a simple telescope using two lenses. Mount the source (illuminated arrow) and the screen on the optical bench, and mount one of the lenses between them. Adjust their positions until a real image of the arrow is focused on the screen. For best results, adjust the positions so that the lens is about half-way between the object and the image. Measure p and q . Calculate f from the thin lens equation,

$$\frac{1}{f} = \frac{1}{p} + \frac{1}{q}.$$

Repeat for the other lens. Record your results below.

Construct a telescope by mounting the two lenses a distance $f_1 + f_2$ apart. Use the lens with the smaller focal length for the eyepiece. View the large scale mounted on the wall across the room. The distance between the two lenses may be adjusted to bring the image into better focus.

Measure the angular magnification m of the telescope by viewing the scale through the telescope with one eye and looking directly at the scale with the other eye. In this way, you ought to be able to see both the magnified and unmagnified scale superimposed on each other. Finally, calculate m from the measured focal lengths.

	lens 1	lens 2
$p =$	_____	_____
$q =$	_____	_____
$f =$	_____	_____
$m =$	_____	measured
$m =$	_____	calculated

Due: Friday, June 5

Physics 123
Lab #7
Diffraction Grating

Identification number _____

In this lab, you will observe the interference pattern produced by shining a laser beam through a diffraction grating. From the distance between peaks in the pattern, you will determine the distance between the slits in the grating.

The He-Ne laser used in this lab produces red light of wavelength 633 nm. Turn on the laser. Its beam should pass through the diffraction grating. You should observe the interference pattern on the wall.

Use a meter stick to measure the distance Δx between peaks in the interference pattern. Average this distance over several adjacent peaks so that your measurement will be as accurate as possible. Record your result below.

Use the tape measure to determine the distance L between the diffraction grating and the interference pattern on the wall and record your result below.

Calculate the angle θ between adjacent bright spots in the interference pattern and record your result below.

Using $d \sin \theta = \lambda = 633 \text{ nm}$, calculate the distance d between the slits in the grating and record your result below.

$\Delta x =$ _____

$L =$ _____

$\theta =$ _____

$d =$ _____

Due: Friday, June 5

Physics 123

Identification number _____

Lab #8

Michelson Interferometer

In this lab, you will use a Michelson interferometer to measure the index of refraction of a gas. A chamber which can be evacuated is placed in one arm of the interferometer. All of the air is first evacuated from the chamber. As the gas to be studied is slowly allowed to enter the chamber, the number of fringes passing by the center of the screen is counted.

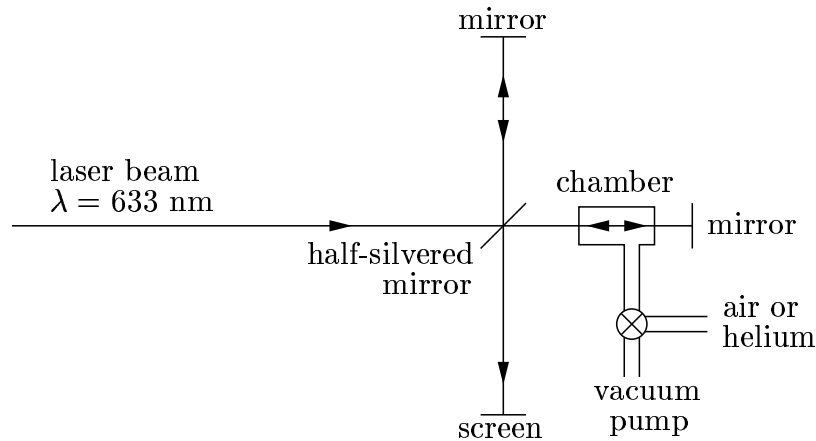

The index of refraction n of the gas is given by

$$n = 1 + \frac{N\lambda}{2L},$$

where N is the number of fringes counted, λ is the wavelength of the laser in vacuum, and L is the length of the chamber.

Turn on the vacuum pump and evacuate the chamber. Pump for at least a couple of minutes to obtain a good vacuum. Valve off the vacuum pump and *slowly* open the chamber to air and count the fringes. (You will probably open the valve too fast the first time you try, and the fringes will go by too quickly to count. If this happens, evacuate the chamber again and start over.) Repeat using helium gas instead of air. Measure L and calculate n for each gas.

	Air	Helium
$L =$	_____	_____
$N =$	_____	_____
$n =$	_____	_____

Physics 123
Supplement to Lab #8
Michelson Interferometer

When the chamber is evacuated, the number of wavelengths along its length L is given by

$$N_{\text{vac}} = \frac{L}{\lambda_{\text{vac}}}, \quad (1)$$

where λ_{vac} is the wavelength of the laser light in vacuum. When the chamber is filled with some gas, the number of wavelengths along its length is now given by

$$N_{\text{gas}} = \frac{L}{\lambda_{\text{gas}}}, \quad (2)$$

where λ_{gas} is the wavelength of the laser light in the gas.

Each time one arm of the interferometer gets behind (or ahead) by one wavelength, one fringe passes by the screen. As we fill the chamber with gas, that arm of the interferometer will get behind by $N = 2(N_{\text{gas}} - N_{\text{vac}})$ wavelengths. (The factor 2 is included since the light passes through the chamber twice, once going and once coming back.) From equations (1) and (2), we thus obtain

$$N = 2 \left(\frac{L}{\lambda_{\text{gas}}} - \frac{L}{\lambda_{\text{vac}}} \right). \quad (3)$$

We also know that

$$\lambda_{\text{gas}} = \frac{\lambda_{\text{vac}}}{n},$$

where n is the index of refraction of the gas. Putting this into equation (3) solving for n , we obtain

$$n = 1 + \frac{N\lambda_{\text{vac}}}{2L}.$$

Due: Friday, June 12

Physics 123
Lab #9
Photoelectric Effect

Identification number _____

In this lab, you will measure Planck's constant, using the photoelectric effect. At one end of the apparatus is a mercury lamp. The housing around the lamp can be rotated, placing various filters in front of the lamp. A lens focuses the light on the emitter (E) of a photomultiplier tube. The photons in this light eject electrons from the emitter. Some of the electrons fall on the collector (C), charging it up and building a potential difference V between E and C. Eventually, V becomes so large that the collector repels *all* electrons ejected from the emitter. At this point, V reaches a steady-state value V_c such that eV_c is equal to the maximum possible kinetic energy K_{\max} of the electrons ejected from the emitter. From the textbook, we find that $K_{\max} = hf - \phi$, where f is the frequency of the light and ϕ is the work function of the emitter. If we plot K_{\max} as a function of f , we ought to obtain a straight line.

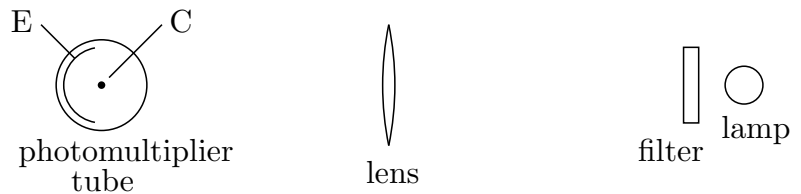

Put the light shield on the apparatus to prevent room light from striking the photomultiplier tube. Rotate the filter assembly to obtain the various wavelengths λ of light. For each wavelength, measure V_c using the high-impedance voltmeter provided. You must reset the voltmeter for each new V_c . Record the results below and plot the data on the graph. (Note: if $V_c = 1$ volt, then $K_{\max} = eV_c = 1$ eV.) Using a straight-edge, draw a straight line through the data points. From the x -intercept and slope of this line, find the work function ϕ (in eV) of the emitter and Planck's constant h . (Don't try to obtain the y -intercept directly from the graph.)

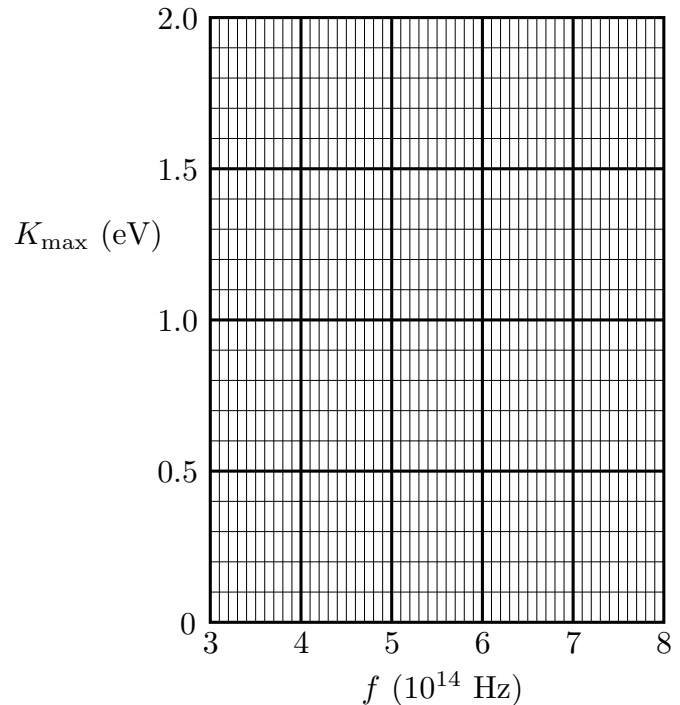

λ	f	K_{\max}
_____	_____	_____
_____	_____	_____
_____	_____	_____
_____	_____	_____

$\phi =$ _____

$h =$ _____

Due: Friday, June 12

Physics 123
Lab #10
Hydrogen Spectrum

Identification number _____

In this lab, you will observe the spectrum from an excited sample of hydrogen gas. The spectrum lines arise from electron transitions between energy levels in the hydrogen atoms given by

$$E_n = -\frac{13.6 \text{ eV}}{n^2},$$

where n is a positive integer. If the electron is in an excited state ($n_i > 1$), it can fall to a state of lower energy ($n_f < n_i$), emitting a photon of frequency f . From conservation of energy, the energy hf of the photon must be equal to the energy lost by the electron: $hf = E_i - E_f$. From $\lambda = c/f$, we obtain the wavelength of the emitted photon:

$$\frac{1}{\lambda} = R_H \left(\frac{1}{n_f^2} - \frac{1}{n_i^2} \right), \quad (1)$$

where $R_H = 1.0973 \times 10^7 \text{ m}^{-1}$ is the Rydberg constant. In this lab, you will observe two of these transitions using a diffraction grating mounted on a spectroscope. You will view a source of excited hydrogen atoms through the diffraction grating which will separate the light into "spectral lines". The relationship between the wavelength λ of each spectral line and the angle θ between the directions of the incident and diffracted light is given by

$$d \sin \theta = m\lambda, \quad (2)$$

where $d = 1657 \text{ nm}$, the distance between lines on the grating, and m is an integer. Looking into the spectroscope, you ought to be able to find a red line and blue line on each side of the central maximum ($m = \pm 1$). (If you look carefully, you may be able to see one or more violet lines too.) For each line, record the angles, θ_1 and θ_{-1} for $m = 1$ and $m = -1$, respectively. (Note that the direction $\theta = 0$ is marked 180° on the spectroscope. The value of θ which you should record below is the *difference* between 180° and the angle indicated on the spectroscope.) If you performed the measurements correctly, you should have $\theta_{-1} \approx -\theta_1$. Because of errors inherent to the spectroscope, the two angles, θ_1 and θ_{-1} , may not have exactly the same magnitude. In order to remove this source of error, calculate the average $\bar{\theta}$ of the magnitudes of the two angles [$\bar{\theta} = \frac{1}{2}(|\theta_1| + |\theta_{-1}|)$] and then calculate the measured value of λ for each line, using $\bar{\theta}$ in Eq. (2) above. Also, calculate the theoretical value of λ for each line, using Eq. (1) above.

Color	n_i	n_f	θ_1	θ_{-1}	$\bar{\theta}$	λ (measured)	λ (theoretical)
blue	4	2	_____	_____	_____	_____	_____
red	3	2	_____	_____	_____	_____	_____